

# Mini-Chemical Regulator

Model: G S C R 4 -

## Instruction Manual

### <Product Overview>

#### • Usage

Semiconductor, pharmaceutical, and chemical engineering applications

#### • Features

- A compact decompression control valve for DI Water and chemicals.
- Remote control type by means of air controls.
- The wetted part is highly corrosion resistant with the use of fluorocarbon resin and can be used with a wide range of chemical agents.

### <Read Before Use>

**Since this product falls under the category of commodities related to chemical weapons specified in the Foreign Exchange and Export Trade Control Order, proper export licenses will be required.**

### WARNING

- Check the type of liquid to be used and its compatibility with the wetted part of the valve before using.
- Be sure to read and understand this manual before using this product.
- Please keep this manual in a safe and convenient place where it can quickly be referred to when necessary.
- Use the product only as intended, and only as directed in this manual.
- Cautionary notes in this document must be fully understood and complied with at all times.



### <About This Operation Manual>

- The contents of this manual are subject to change without prior notice due to improvements in product functionalities and/or performance.
- Unauthorized reproduction or duplication of all or any part of this instruction manual is prohibited.
- Please notify us if you have misplaced this operation manual.
- Please notify us if you find unclear, incorrect, and/or omitted descriptions in this manual.

### For Your Own Safety

### <Symbols in This Operation Manual>

The meaning of the symbols in this manual are as described below.

|   |  |
|---|--|
|  <b>WARNING</b> | This symbol indicates warnings which may result in death or severe injury to the user if not observed.             |
|  <b>CAUTION</b> | This symbol indicates warnings which may physically impair the user or damage surrounding objects if not observed. |
|                | This symbol indicates important notes or notes on properly operating the product.                                  |

### Warnings

Be sure to read and follow the warning items below before using this product.

### <Working and Handling Conditions>

### WARNING

- Do not dismantle this product. The product may fail to operate properly.
- This product was developed and designed as a secondary pressure control 2 valve. Do not use this valve as a check valve or ON/OFF valve.
- Do not use this product with liquids containing dirt or foreign substances.  
The performance of this product may decline as a result.

### 1. Installation and Plumbing

Please conduct the installation and piping according to the following warning items.

### CAUTION

- Please conduct the piping work so that bending moment is not applied to the operation port's fittings.
- When attaching the product to surfaces like walls etc., if the IN side is facing up and the OUT side is facing down, the flow rate may drop as the air inside the plumbing is not fully released.
- Do not use this product in a location subject to strong vibration or shock. There is a risk that the product may fail to function properly.
- Please securely fix the body using the 4 mounting holes on the base of the product. Otherwise, accidents resulting from falling objects may occur.
- When piping, please refer to the flow direction of the arrows ( ) on the frame prior to doing the actual IN/OUT piping work. If the piping for IN/OUT is done backwards, the product may fail to function properly.
- Do not use a piping method that will cause bending stress or tensile stress to be applied. Otherwise, the liquid may leak.
- Regarding work on the fittings, please refer to the catalog and operation manuals of the fitting manufacturer.

### 2. How to Use

The secondary side pressure is set by changing the operation air pressure. Please control by applying air into the operation port on the upper part of the main body. Please adjust the operation air pressure using precision regulators and electric pneumatic regulators.

#### 2-1 Air release

- (1) After installation, apply air inside the operation port and release air inside the ducts of the main body by injecting a fluid from the body's IN side.
- (2) Confirm that bubbles are no longer generating on the OUT side.

#### 2-2 Setting the Secondary Pressure

When the operation air pressure is increased, the secondary pressure rises, and likewise, if the operation air pressure is decreased, the secondary pressure will drop.

### CAUTION

- Please use this product within the range of the flow rate and pressure listed in the specifications. Otherwise, damages or accidents may occur.
- Always use the product while applying load to the secondary side. Otherwise, the secondary side pressure cannot be controlled.
- Please use the product with the secondary side pressure in a lower state than the primary pressure. Otherwise, the flow rate will drop.
- Please release all air completely from inside the ducts of the main body. Otherwise, the flow rate will drop.
- Always set the operation air pressure within the specified range. Otherwise, breakdown or damage may occur.



Please do not use this product under conditions where there are sudden fluid temperature changes, otherwise the product may break down.

## 3. Specifications

|                                       | GSCR4-3P300P   | GSCR4-4P300P      |
|---------------------------------------|--|-------------------|
| Material of wetted part               | PFA, PTFE  |                   |
| Fluids used                           | DI Water, chemicals  |                   |
| Temperature range of fluid            | 10 ~ 90  |                   |
| Environmental temperature range       | 10 ~ 60  |                   |
| Primary side pressure                 | 100 ~ 500kPa   |                   |
| Secondary side pressure setting range | 50 ~ 300kPa* Depending on conditions                       |                   |
| Withstanding pressure                 | 600kPa   |                   |
| Operating pressure                    | 400kPa(MAX)  |                   |
| Flow area                             | 1 ~ 10L/min  | 1 ~ 15L/min       |
| Connection tube size                  | 3/8 ( 9.53 × 6.35)   | 1/2 ( 12.7 × 9.5) |
| Joint type                            | Nippon Pillar Packing Co., Ltd. Super 300 Type<br>P Series |                   |
| Operation port                        | Rc1/8  |                   |

<Dimensional Outline Drawing>

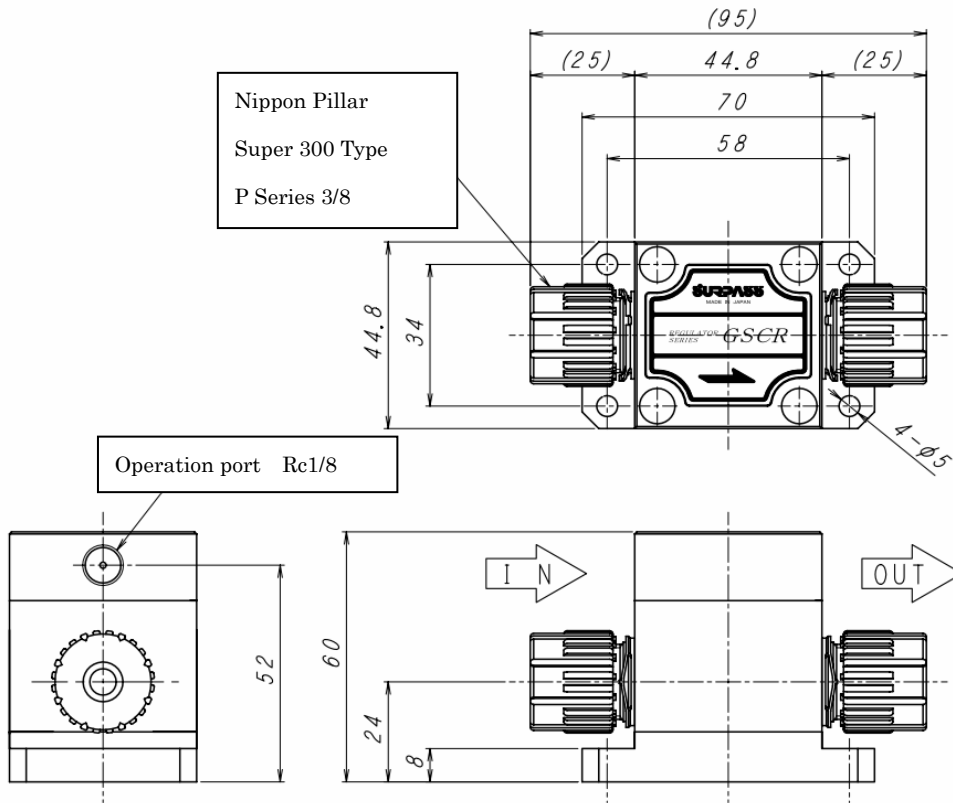

< GSCR4-3P300P >

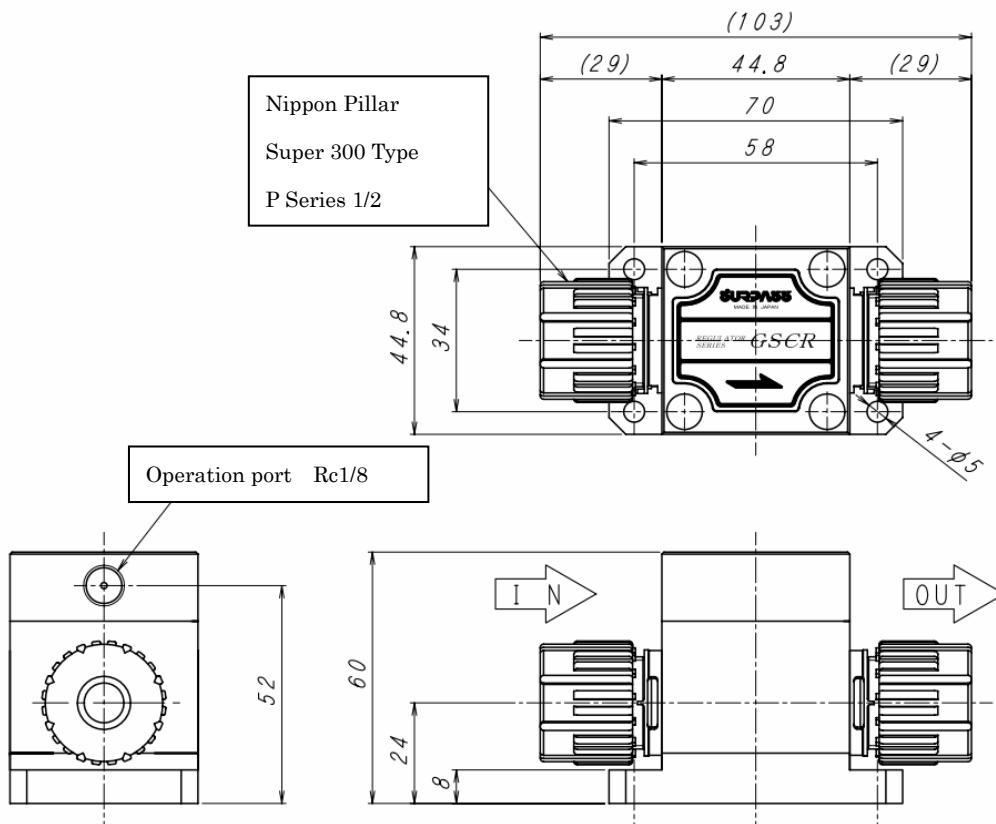

<GSCR4-4P300P>

## 4. Notes on Warranty

This product has been submitted to strict tests and inspections prior to delivery, and is covered with a free-repair guarantee for the period of one year from date of product delivery. During this period, Surpass Industry will provide free repair service for all breakdowns which we acknowledge in writing as designer/manufacturer's responsibility. The warranty shall not be applicable if the product is handled incorrectly, modified, not used as described in this manual, or not operated in compliance with recommendations and instructions by Surpass Industry.

Surpass Industry shall not be held liable or offer guarantees for incidental or consequential damages resulting from the use of its products under situations beyond the conditions of their specification, nor does it guarantee the performance of other products used in combination with its products. Compensation based on the Surpass warranty is limited to the replacement of the product itself.

However, the warranty is voided (i.e. the customer pays for repairs) in case of the following.

- Breakdown or damage caused by product handling or usage that does not comply with the product's operation manual.
- Breakdown or damage caused by careless handling or usage of the product.
- Breakdown or damage caused by disassembly or alteration, or inappropriate adjustment or repair of the product.
- Breakdown or damage caused by natural disasters or other acts of God.
- Replacement of consumable articles or accessories.

< CONTACT >

**SURPASS**

SURPASS INDUSTRY CO., LTD

2203 Shimooshi, Gyoda-shi Saitama-ken 361-0037

Phone: 048(554)9760 FAX: 048(554)9906

URL: <http://www.surpassindustry.co.jp>

© 2012 Surpass Industry Co., Ltd. All rights reserved.